

Sliding Gate Opener

GENIOS 350-KIPP

-mechanic-

Fitting instructions



BELFOX

STARKE TORANTRIEBE

Forsthaus 4

D - 36148 Kalbach

Tel.: 0 900/1101913

Fax: 0 66 55 / 96 95-31

e- mail: info@belfox.de

www.belfox.de

Dear customer,

we thank you for the confidence you put in us in buying a BelFox sliding gate opener „Genios 350-KIPP“.

Already during the fitting process (test run) you will notice that this has been the right decision.

When fitting the operator, please follow the instructions step by step and you will see that fitting this sliding gate opener is very easy to do.

Contents

1. Technical data
2. Delivery range
3. Assembly and disassembly of the console
4. System definition
5. Selection of driving system
6. Fitting instruction
7. Foundation requirements
8. Fitting to the gate
 - 8.1 No premounted toothed rack at the gate
 - 8.2 Premounted toothed rack at the gate
9. Function and adjustment of reference switch
10. Setting into operation / adjustment of motor control
11. Emergency release in case of power failure
12. Safety information
13. EC declaration of conformity Genios 350-KIPP (47-21-0)
14. EC declaration of conformity Genios 350-KIPP (47-21-i)
15. Declaration for installation of a partly completed machine
16. Test book

1.) Technical data

Typ:	Genios 350-KIPP	Genios 350i-KIPP
motor power:	0,21 kW	0,21 KW
mains supply:	230 V / 50...60 Hz	230 V / 50-60 Hz
opening and closing speed:	18 cm / sec.	18 ^{cm} /sec.
thrust and tractive power :	400 N	400 N
max. size / weight of gate:	6 m / 350 kg	6 m / 350 kg
motor voltage:	24 V DC	24 V DC
drift system:	for toothed rack module 4	for toothed rack module 4
post dimensions:	150 x 150 mm	150 mm x 150 mm
post height:	1250 mm, other heights on demand	1250 mm, other heights on demand
dimension of base plate:	155 x 155 x 10 mm Or: 250 x 160 x 10 mm	250 mm x 160 mm x 10 mm (l / b / h)
wall thickness, material:	3 mm aluminium	3 mm aluminium

2.) Delivery range

aluminium column
driving unit, fitted inside
radio receiver
radio transmitter 4-channels
flagpole antenna
emergency release device



easy-click-magnets



radio transmitter 4-
channels (Art.-
No.:7834)

3.) Assembly and disassembly of the console

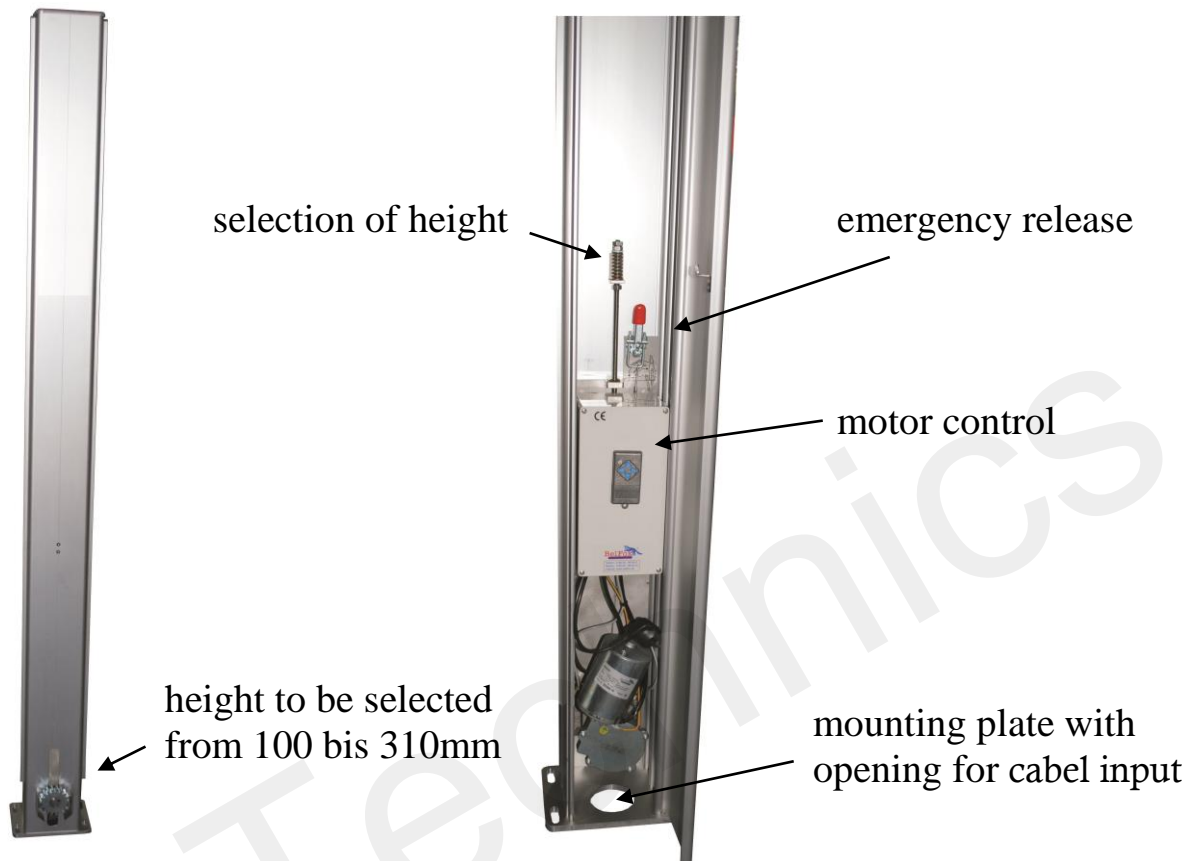

4.) System definition

The driving post by BelFox is a complete unit, ready to fit. It consists of an aluminium post, a base plate welded onto the post, and a driving unit integrated into the post.

This driving unit is reachable through the lockable revision door. Motor control and low-current toroidal transformer are inside a water proof casing which is also integrated into the column. At the upper end of the column is an aluminium cover which you please stick to the column after you have finished the fitting process.

The driving unit is pre-assembled and can be set into operation after the plug is connected to the socket.

The limit position is effected by counting of impulses, integrated in the gearmotor, together with one reference sensor.

Attention: In case of commercial use, please inform yourself about necessary safety devices according to the regulations for power driven windows, doors and gates.

We recommend the fitting of these safety devices also in case of private use.

5.) Selection of driving systems

You have the choice of two driving systems for this sliding gate opener:

- a) toothed plastic rack with steel core for a particularly smooth movement of the gate
- b) toothed metal rack to be welded or screwed onto the gate

6.) Fitting instruction

Genios 350-KIPP is applicable to both ground guided sliding gates and cantilever sliding gates. In both cases the following requirements have to be fulfilled: It has to be a smooth running door with perfect guiding appliances. Guide bows for the gate are available on option (art.-no.608-T).

The gate has to have limit stops at both limit positions to ensure that in case of release it is impossible to push the gate by hand out of its guidance. The driving motor is self-locking, so you do not need any lock.

7.) Foundation requirements

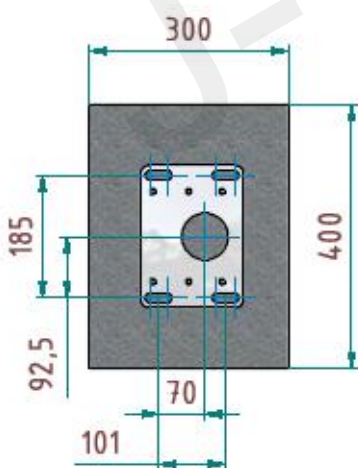

For fastening Genios 350-KIPP to the ground, a concrete foundation or a metal console is necessary. The overall size of the base plate is 250 x 160 mm. Make sure that the foundation is sufficiently sized, so that none of the material will break off when drilling the mounting holes.

8.) Fitting to the gate

When fitting Genios 350-KIPP, take care that the teeth of the toothed rack well engage into the teeth of the driving pinion. Poor engagement shortens the working life of the operator and could lead to teeth being missed out.

8.1 No premounted toothed rack at the gate:

Push the gate manually into OPEN position

Now put the toothed rack onto the drive pinion, push it onto the pinion and draw the mounting holes on to the gate. Then move the gate into direction CLOSE. Draw the mounting holes when the pinion is directly under the mounting hole. It guarantees you to have always the right distance of the pinion to the toothed rack.

8.2 Premounted toothed rack at the gate:

Push the gate manually into OPEN position.

Now release all screws of the toothed rack. Then move the gate step by step into direction CLOSE, as soon as a screw is above the pinion, push the toothed rack manually on the pinion and fix the screw.

Fix at any place of the way of the gate the easy click magnets.

Now the screw for the adjustment of the height has to be put with the help of a ratched or an adequate key, the pinion in the according height.

ATTENTION: Do not use a cordless screwdriver to adjust the height selection! Therefore the adjustment gauge, that is fixed with a screw next to the height adjustment within the unit, must be put between the twists of the pressure arm. The unit must be bent up until the adjustment gauge can be removed and fit into with a light resistance between the twists.

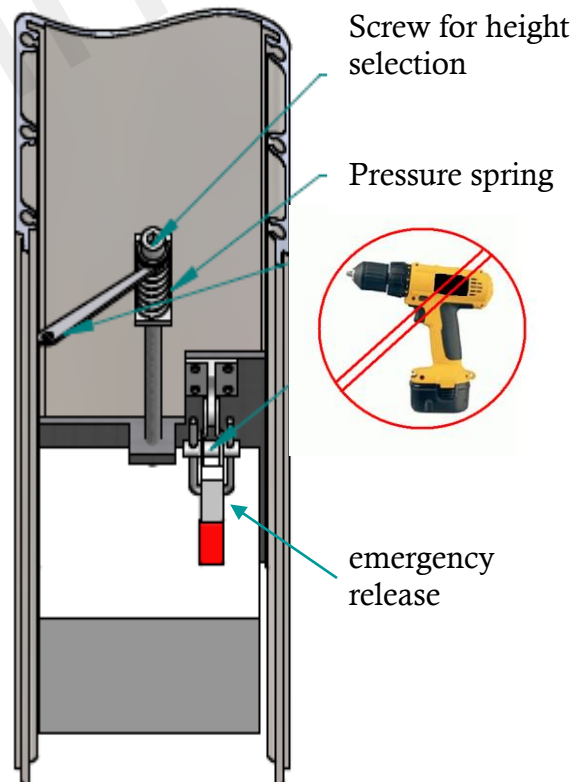

9.) Function and adjustment of the reference switches

Genios 350-KIPP -serie is equipped with contactless limit switch. The reference switch is fixed at the console.

The distance between magnetic switch and magnet must not exceed 10 mm! If the range of the magnet is insufficient, you can either replace it with a stronger magnet.

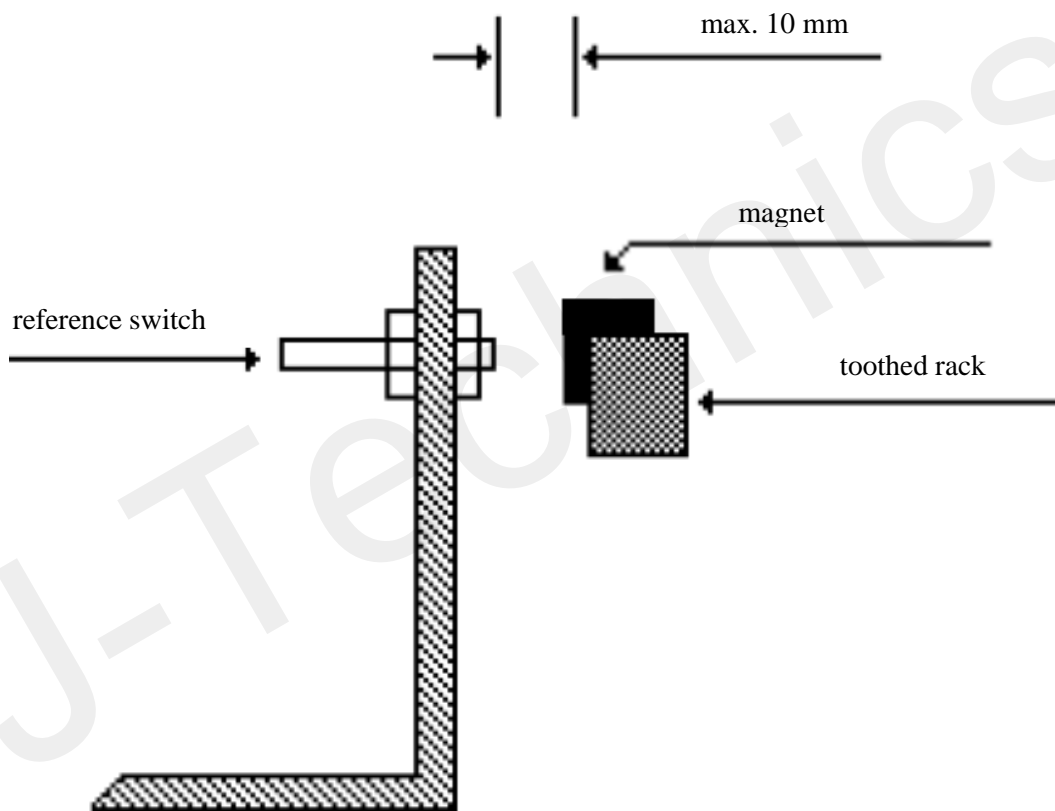

10.) Setting into operation / adjustment of motor control

The electric installation is to be done as described in the instruction manual 47-21-0 or 47-21-I.

11. Emergency release in case of power failure:

To move the gate by hand you must release the gate. To release the operator, pull the lever from his horizontal position to vertical position.

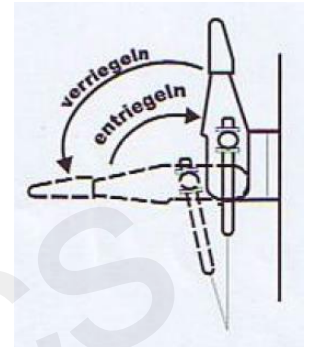

12.) Safety information

This safety information must be handed over to the user as an essential part of the product. It should be read carefully since it contains important notes for the safety at the installation, use and maintenance of the system. The information has to be kept in a safe place and must be put at all further users' disposal.

This product may only be used for the purpose the manufacturer intended it for. Any other use has to be considered as improper and therefore as dangerous. The manufacturer is not legally liable for damages caused by improper use. During the opening and closing process it is not allowed to enter the operative range of the gate.

In case of malfunction you have to switch the system off at the main switch and consult specialist staff. It is not allowed to try to repair the system by oneself. Contravention may lead to situations of danger. All cleaning, maintenance and repair works have to be done exclusively by specialist staff. To guarantee the correct function of the system it is necessary to maintain it regularly by specialist staff according to the instructions of the manufacturer. Especially the correct function of the safety devices has to be checked regularly. All installation, maintenance and repair works have to be reported in a log book.

13. EC – Declaration of conformity

Producer/ technical documentation name and address:

**BelFox Torautomatik GmbH
Forsthaus 4
36148 Kalbach**

We hereby declare that the gate opener

**Type: Genios 350-KIPP
with motor control unit 47-21-0**

is conform to the following directives:

**EMV – directive 2014/30/EU
European machinery directive 2006/42/EG
Directive low voltage 2014/35/EU
Radio equipment directive RED 2014/53/EU
RoHS directive 2011/65/EU**

Applied harmonized standards, which have been published in the office journal of EU are:

**DIN EN 61000-6-2
DIN EN 61000-6-3
DIN EN 60335-1:2012
DIN EN 60335-2-103**

Applied national norms and technical specifications:

**Reliability of power-operated gates, requirements (EN 12453)
Reliability of power-operated gates, testing method (EN 12445)**

Place: D-36148 Kalbach

Date: 01.02.2018

Signature of the liable person: 

Name and function: Edgar Fierle, managing director

**Page 2 to the EC-Declaration of conformity for
sliding gate operators Genios 350-KIPP.**

**According to the directives mentioned on page 1 and the proof of
accordance of the tested drive with these directives as well as with the test
report of RW TÜV Systems of 24.01.2006 the operation of the drive
Genios 350-KIPP permitted as follows:**

Cantilever or guiding sliding gate

**Operation of the gate in lock function up to a weight of 350 kg and a length
of 6 mtr without active safety edges on the main closing edge (with rubber
buffer type 610-D) and with safety edges type 610-55 on the secondary
closing edge.**

**We state expressly that further safety devices such as photoelectric barriers
might be necessary for the equipment of a power-operated gate.**

14. EC – Declaration of conformity

Producer/ technical documentation name and address:

**BelFox Torautomatik GmbH
Forsthaus 4
36148 Kalbach**

We hereby declare that the gate opener
**Type: Genios 350-i-KIPP
with motor control unit 47-21-i**

is conform to the following directives:

**EMV – directive 2014/30/EU
European machinery directive 2006/42/EG
Directive low voltage 2014/35/EU
Radio equipment directive RED 2014/53/EU
RoHS directive 2011/65/EU**

Applied harmonized standards, which have been published in the office journal
of EU are:

**DIN EN 61000-6-2
DIN EN 61000-6-3
DIN EN 60335-1:2012
DIN EN 60335-2-103**

Applied national norms and technical specifications:

**Reliability of power-operated gates, requirements (EN 12453)
Reliability of power-operated gates, testing method (EN 12445)**

Place: D-36148 Kalbach

Date: 01.02.2018

Signature of the liable person: 

Name and function: Edgar Fierle, managing director

**Page 2 to the EC-Declaration of conformity for
sliding gate operators Genios 350-i-KIPP.**

**According to the directives mentioned on page 1 and the proof of
accordance of the tested drive with these directives as well as with the test
report of RW TÜV Systems of 24.01.2006 the operation of the drive
Genios 350-i-KIPP permitted as follows:**

Cantilever or guiding sliding gate

**Operation of the gate in lock function up to a weight of 350 kg and a length
of 6 mtr without active safety edges on the main closing edge (with rubber
buffer type 610-D) and with safety edges type 610-55 on the secondary
closing edge.**

Deadman function is admissible without any active or passive safety edges.

**We state expressly that further safety devices such as photoelectric barriers
might be necessary for the equipment of a power-operated gate.**

15.) Declaration for installation of a partly completed machine

Within the meaning of the directive 2006/42/EG, Annex II part 1B

Producer/ technical documentation name and address:

**BelFox Torautomatik GmbH
Forsthaus 4
36148 Kalbach**

We hereby declare that the partly completed machine
Sliding gate operator Genios 350-KIPP

as far as it's possible of the scope of delivery, complies to the essential requirements of the following directive

European Machinery Directive 2006/42/EG

Applied harmonized standards, which have been published in the office journal of EU are

**EN ISO 13849-1:2008 Kat.2 / PLc –
Closing force limit and evaluation safety edges
DIN EN 60335-1:2012**

Applied national norms and technical specifications:

**Reliability of power-operated gates, requirements (EN 12453)
Reliability of power-operated gates, testing method (EN 12445)**

Furthermore we declare that the technical documents for this partly completed machine has been created according to VII part B and we oblige to send upon request to the market surveillance authorities via our documentation department.

The partly completed machine must not be put into service until the machinery is integrated in a machine which complies with the directives of the EG-machinery directive and for which an EC declaration of conformity according to annex II A is available.

Place: D-36148 Kalbach

Date: 01.02.2018

Signature of the liable person: _____ 

Name and function: Edgar Fierle, managing director

Annex

Requirements of the annex I of 2006/42/EG which are followed. The numbers refer to the parts of annex I:

1.1.2, 1.1.3, 1.1.5, 1.2.1, 1.2.6, 1.3.2, 1.3.4, 1.3.7, 1.3.9, 1.5.1, 1.5.6, 1.5.11, 1.7.1, 1.7.1.1, 1.7.2, 1.7.3, 1.7.4, 1.7.4.1, 1.7.4.2 (partly)



TYP: Genios 350-KIPP

Serial-No.: _____

Date of purchase: _____

Stamp of supplier and signature

Further BelFox products:

Operators for garage doors
Operators for swing gates
Operators for sliding gates
Drive portals
Barriers and accessories
Radio control units
Switch elements-
Particular drives

16.) Test book

The test book for this operator can be printed out via our homepage www.belfox.de.